

DIOnavi. Master S Kit

Precision & Simple

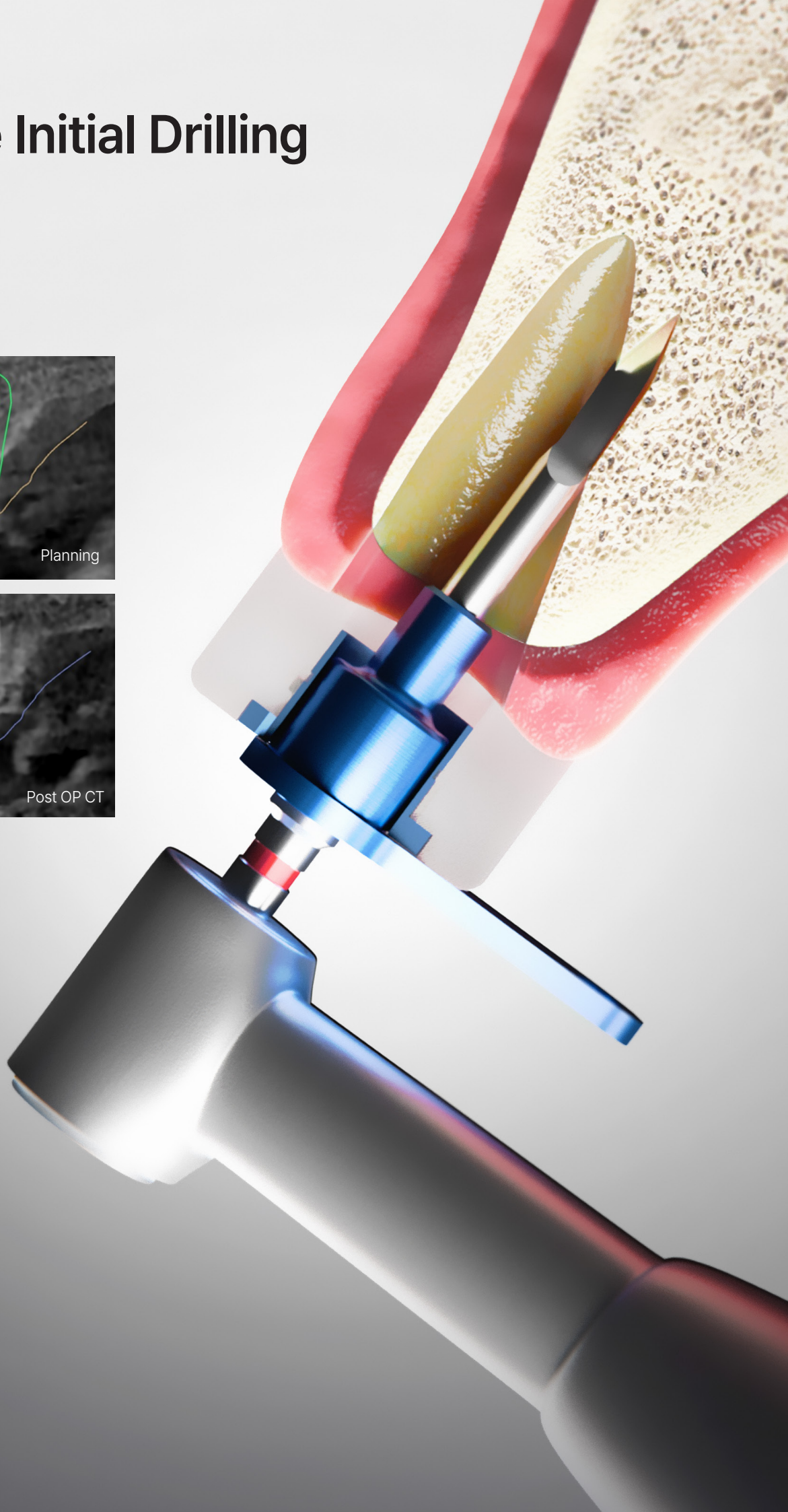

Precise Initial Drilling

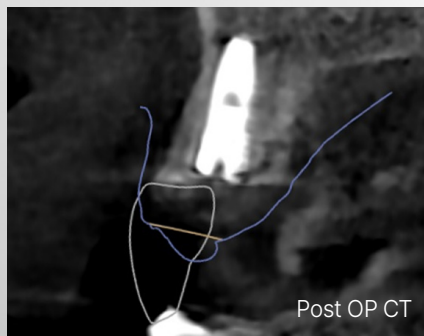
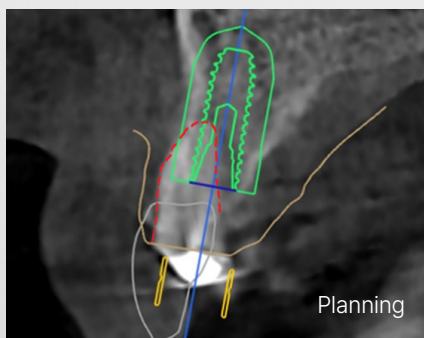

DIOnavi. Full Change! from A to Z!

01

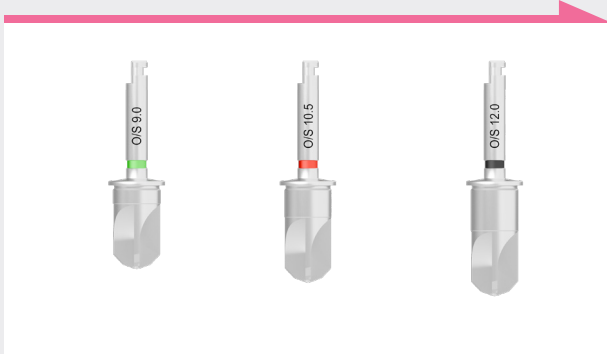

Securing the width of alveolar bone and Flattening it

Deep Bone Flattening Drill

The Flattening Drill has increased cutting efficiency by more than three times.

02

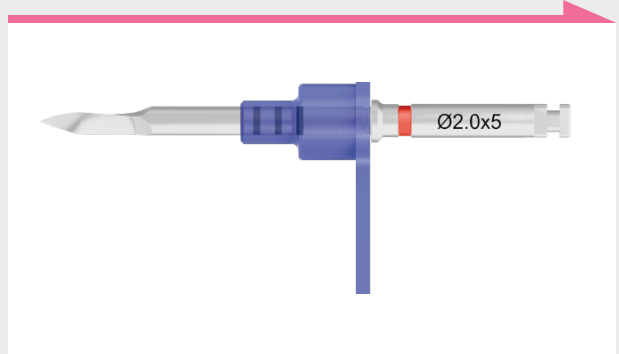

Precise position of the Initial Drill

Initial Positioning Drill

Accurate drilling is possible even in excessively inclined bone.

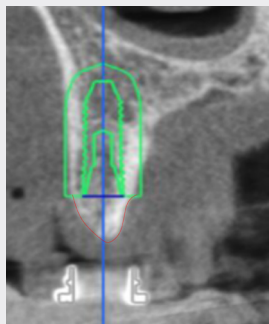
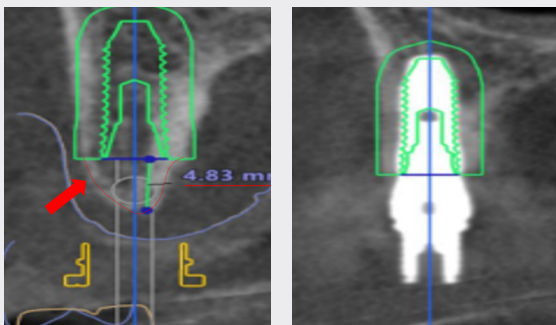

03

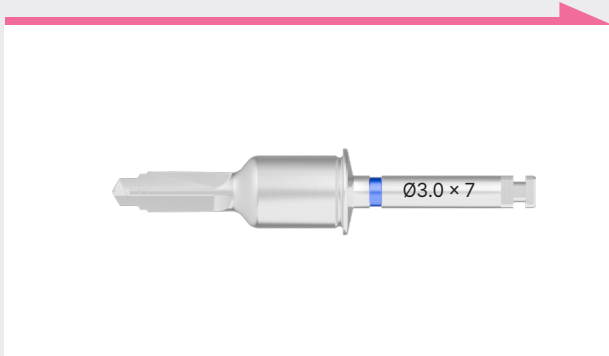

Stable Drilling

Final(Straight) Drill

The 3-step drill design maintains stable double contact even with simplified drilling sequence.

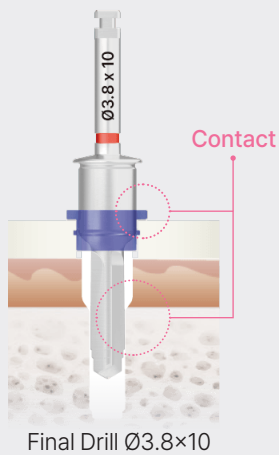

Final Drill Ø3.8x10

04

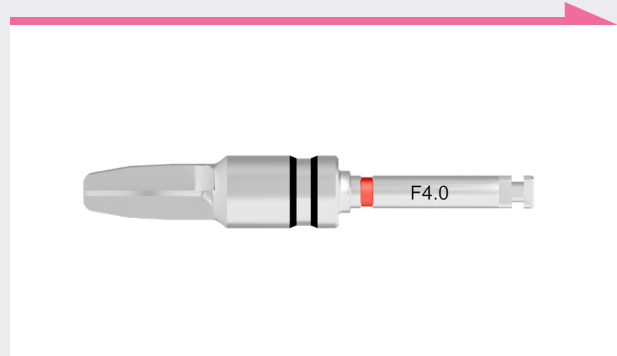

Torque Adjustment

Profile Drill

The Improved Profile Drill can be used with all offsets, providing the additional space required for deep implantation.

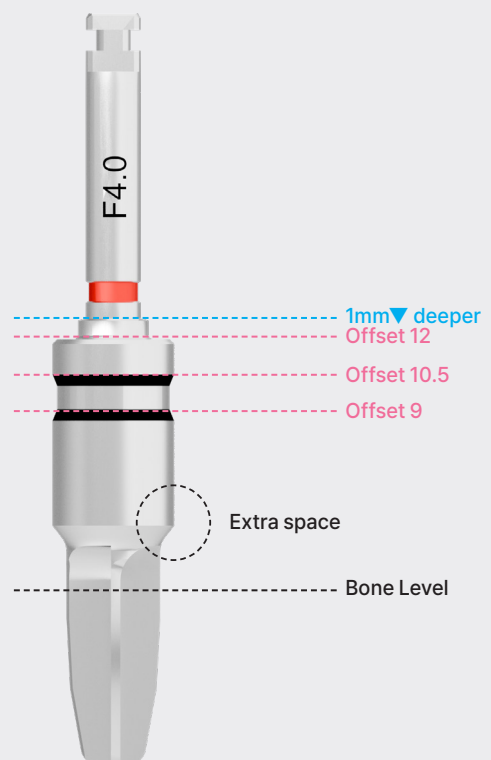

05

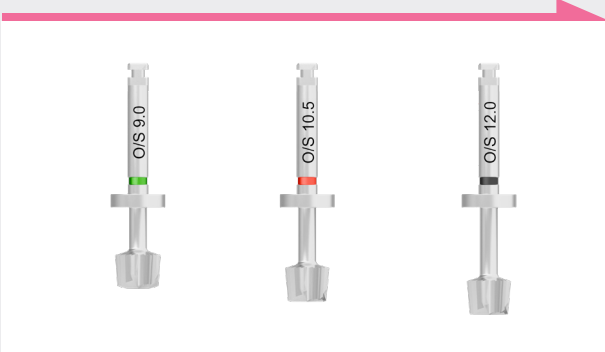

Bone Reduction around the Implant

Guide Side Cut Drill

It enables convenient reduction of the alveolar bone around the implant during deep implantation.

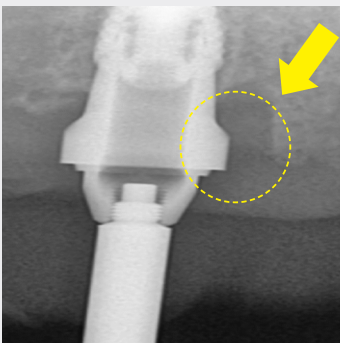

Clinical case by
Dr. Hyunrak Son, Newton Dental Clinic

06

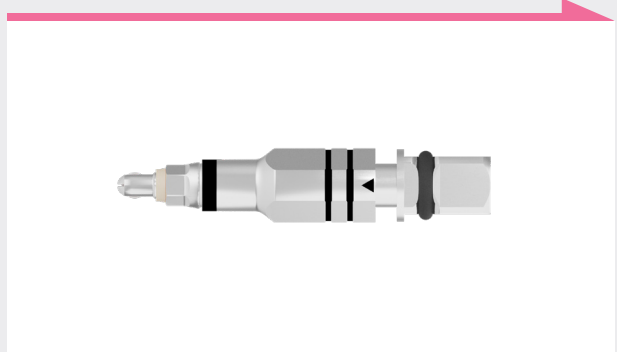

Implantation

Implant Connector

Improved sleeve fitting and increased convenience for implantation.

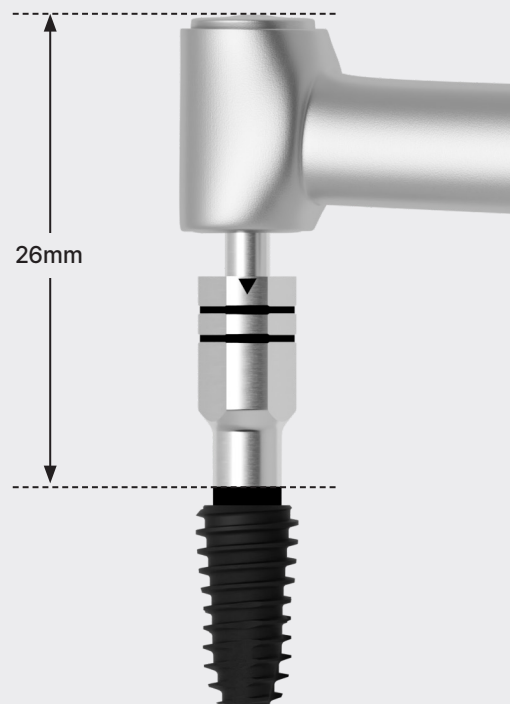

Additional Connector for Machine

Master S Kit

Order Code | UF 77

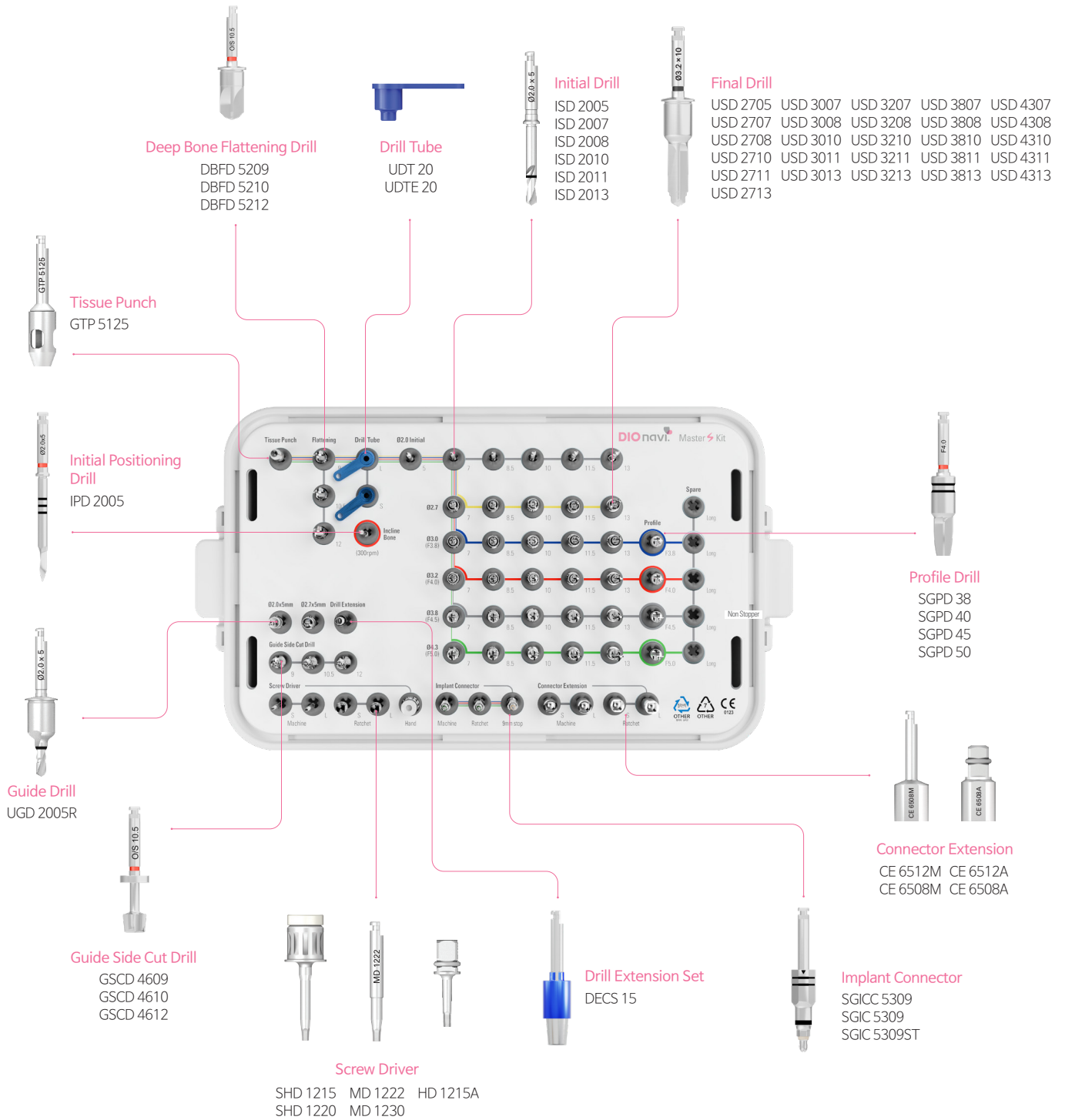

Deep Bone Flattening Drill
DBFD 5209
DBFD 5210
DBFD 5212

Drill Tube
UDT 20
UDTE 20

Initial Drill
ISD 2005
ISD 2007
ISD 2008
ISD 2010
ISD 2011
ISD 2013

Final Drill
USD 2705 USD 3007 USD 3207 USD 3807 USD 4307
USD 2707 USD 3008 USD 3208 USD 3808 USD 4308
USD 2708 USD 3010 USD 3210 USD 3810 USD 4310
USD 2710 USD 3011 USD 3211 USD 3811 USD 4311
USD 2711 USD 3013 USD 3213 USD 3813 USD 4313
USD 2713

Tissue Punch
GTP 5125

Initial Positioning Drill
IPD 2005

Profile Drill
SGPD 38
SGPD 40
SGPD 45
SGPD 50

Guide Drill
UGD 2005R

Connector Extension
CE 6512M CE 6512A
CE 6508M CE 6508A

Guide Side Cut Drill
GSCD 4609
GSCD 4610
GSCD 4612

Drill Extension Set
DECS 15

Implant Connector
SGICC 5309
SGIC 5309
SGIC 5309ST

Screw Driver
SHD 1215 MD 1222 HD 1215A
SHD 1220 MD 1230

Torque Wrench
DTW 0080

DIO IMPLANT
www.dioimplant.com